

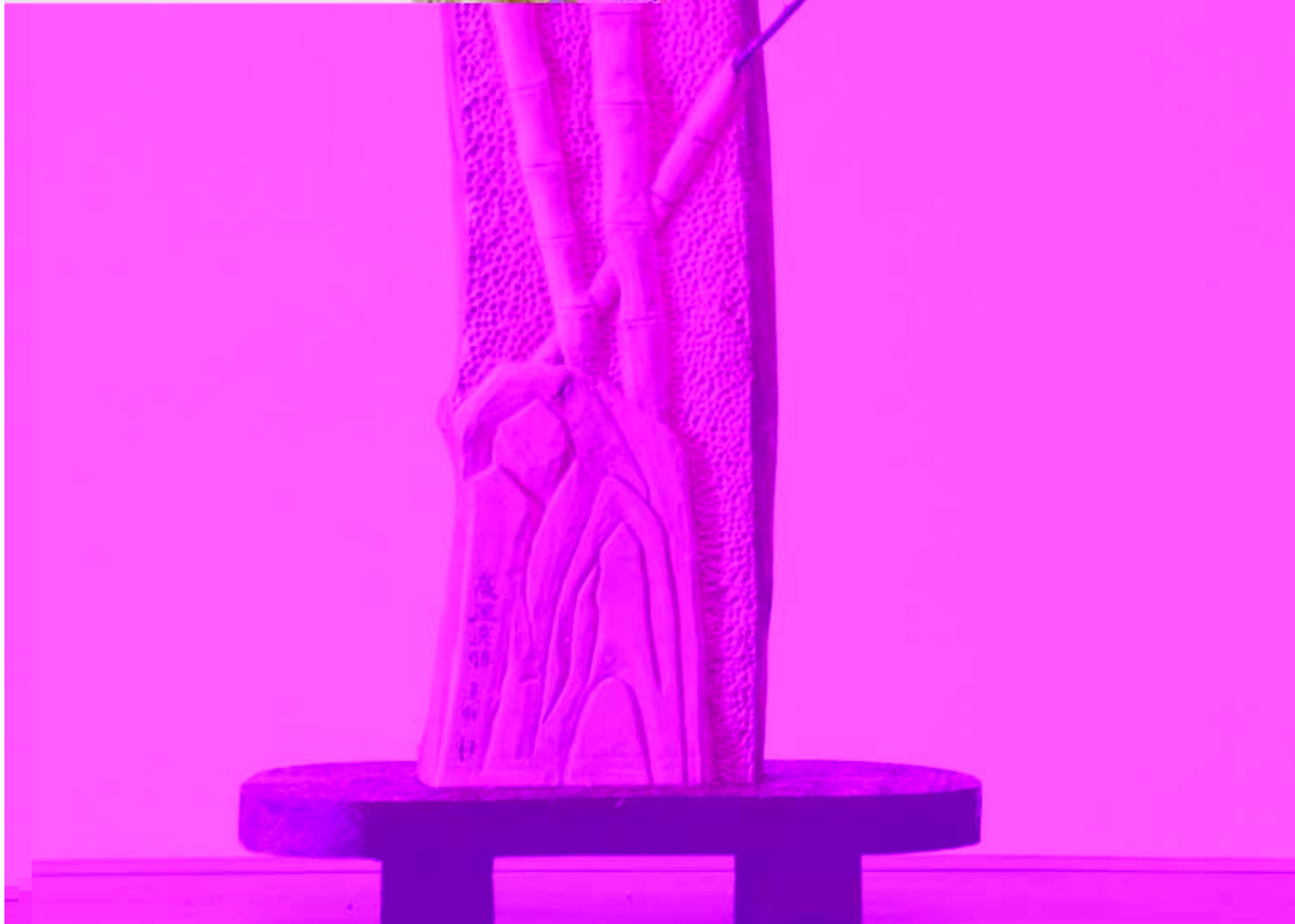

Vocational Education with Originality







卷首

许可

)' (0

)'

)'

)' (/

#

许



contents

P3

#

P6

..

#

P7-16

..

#

..

P17-25

#

&\$%

#

..

P26-29

#

#

P30-33

#

..

#

contents

P48-51

· · · · · #
· · · · · #

P52-57

· · · · · #
ž · · · · · #
· · · · · #

P58-61

P62-67

· · · · · %\$
&\$

P68-89

· · · · · #
· · · · · #
· · · · · #
· · · · · #
· · · · · #
· · · · · #
· · · · · #
· · · · · #

P90-112

ž · · · · · ž · · · · · ž · · · · · ž · · · · ·

..



+

#

)'()

= L

)'(+

)'(. (

)'(. ((

))

) *



)' (/

..... &



)' (/

)

)' (.

)' ('

()''

-''



()*+

)' (/

)' (.

)' (.

)' (/

)' (/

(*

)

)' (/

| / \$ \$ |

...

&\$%



)' (' ,

)' () .
=" L

)' (* ,

)' (+

%&' (

%&' (

)' (/

()*+

\$

\$

\$

()*+

(/

0*

+ (

(/

BKJ

(' .

...



\$ \$ \$

('

(/

BKJ



Pl eq_`C`



Ae^]l `C`



>l f d e`Cl

)' (,

)' (+

)' (,

O/fl

)-/.
(*'

O/fl

O, %fl
, *fl

+*

))

('

)' (+

+

)),

/)(



■

&\$%

%&' ()



▼) C.



.....

.....

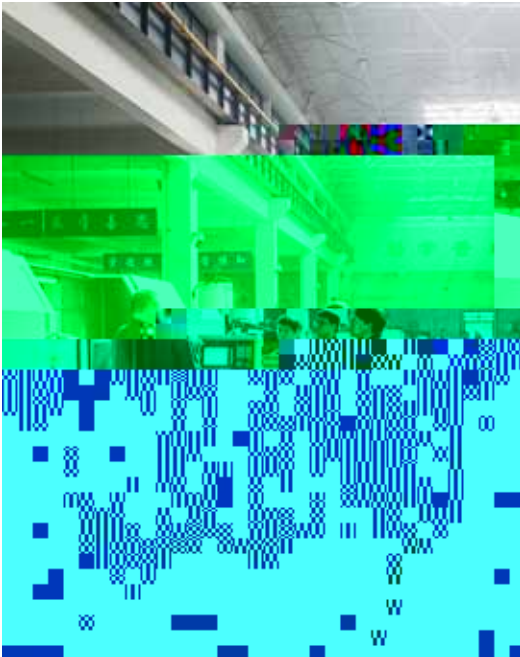

)%

(''

('''

+

)'(.

)*)

-'

)'(.

)')).

)'(. 0

)'(+

+

((

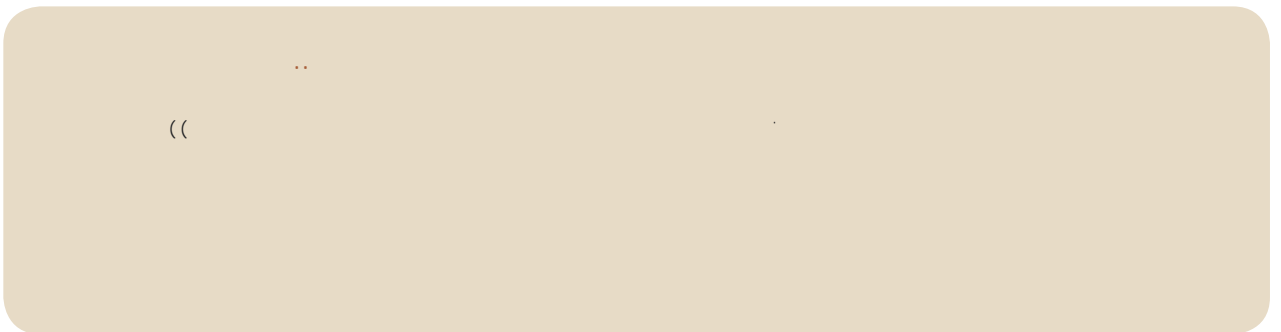



()*+,

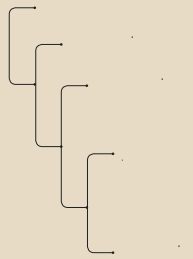

))

ggk



)' (.

+

&



' (. 0

O- fl

+

((

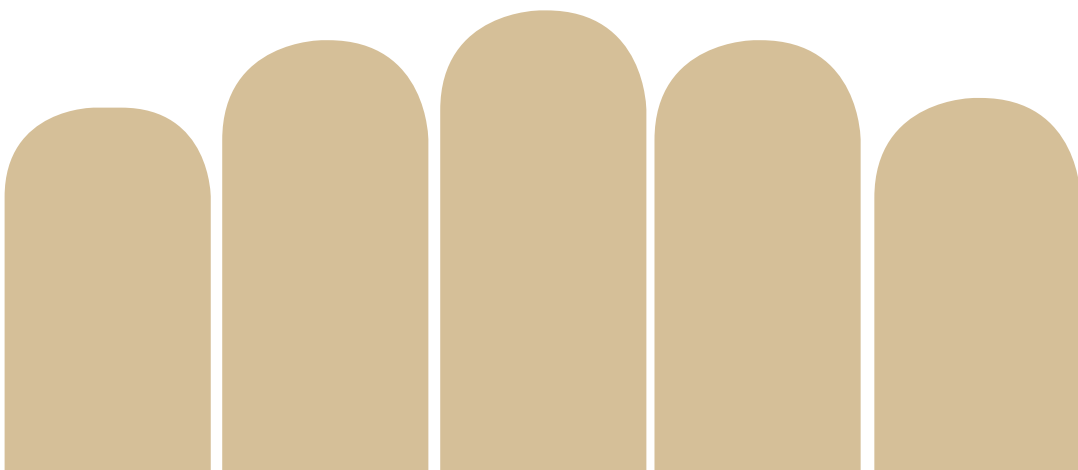



*, ▲

****)%D N G
/**
*_
*_
(,
(*
)'
)'
/'
)' (,

*_
*_
=" L
)-' +
()/
-+'
)' (*
#' ((



山东省创新创业学院

职业院校数字校园建设实验校

节约型公共机构示范单位

销售合作社系统综合改革示范高校

自高等教育技能型特色名校

职业院校国际影响力五十强

学院

实验校

单位

高校

名校

强

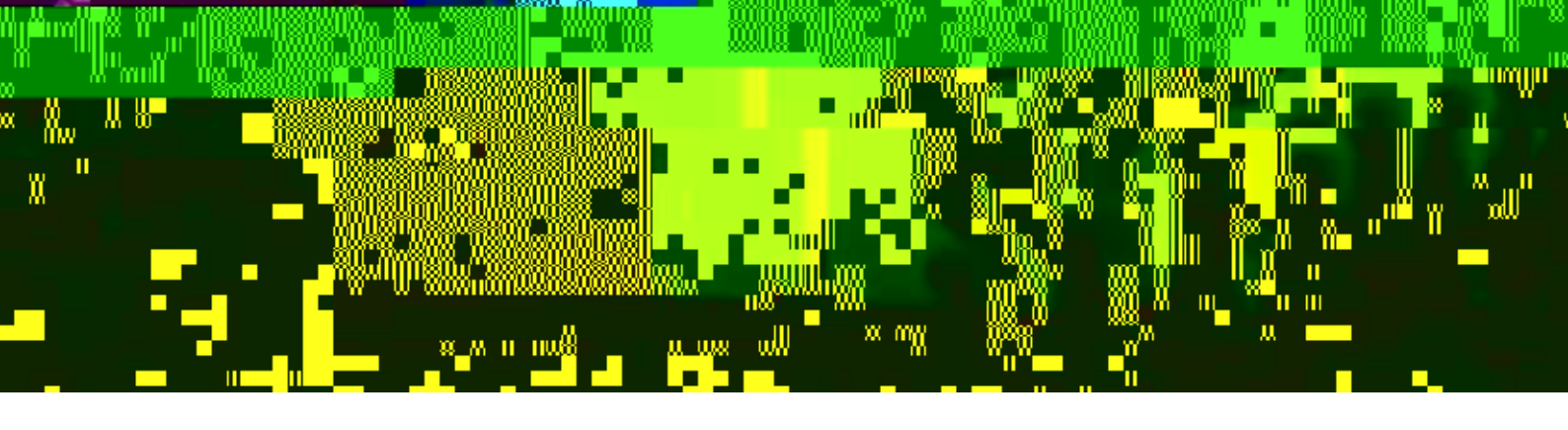

2018 年人才培养质量报告



)(/



(
)
)' (/

*)' (/

+.
(-

(/

()''

\$

*+



/ +'

((

(*

+

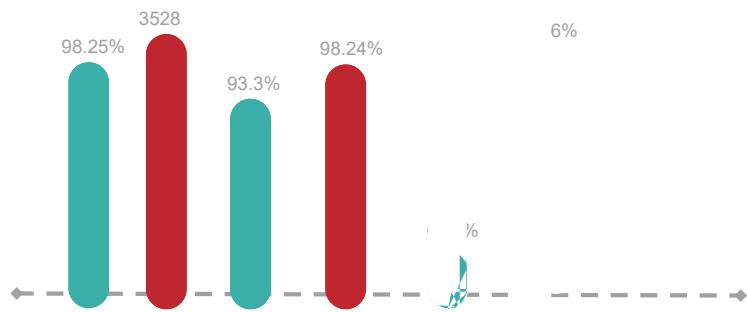

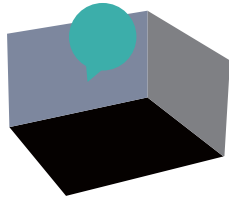

(

)*

+*

(+

+'''

+) (.

-,

/() %

(*

\$

*

(, /

--

(+

00'

-, +%-,

+(

0/,)

(, *(0

)%,

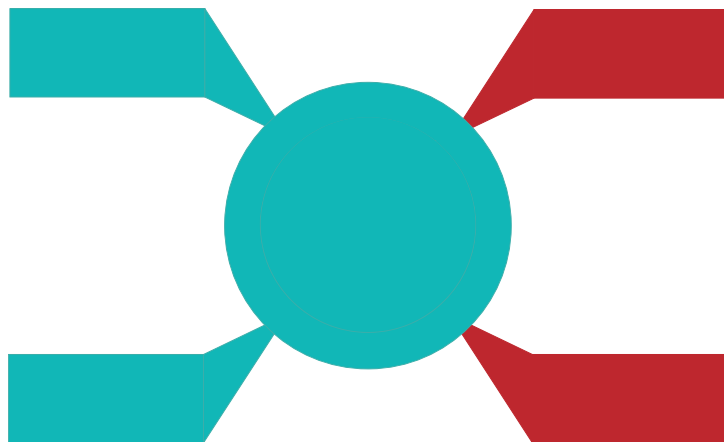
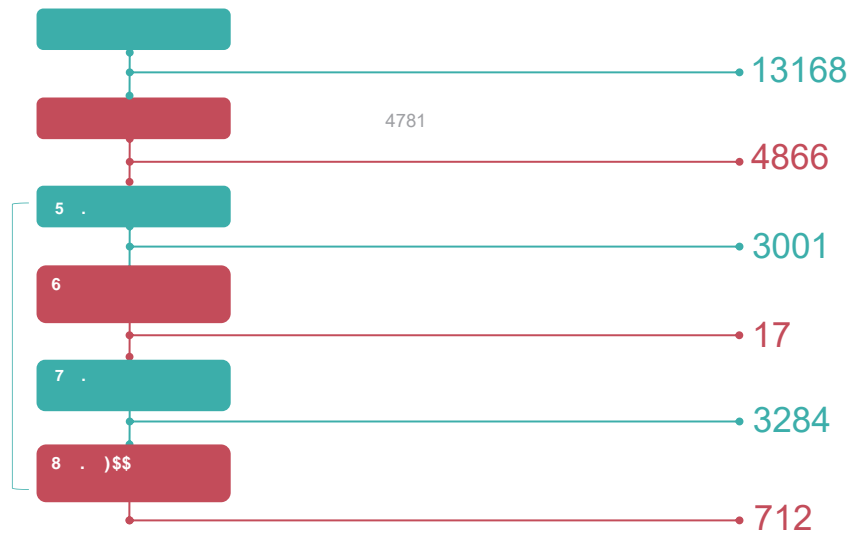

) + \$ \$

... &



(+

(*

)' (/ (

*

(+

)' (/ (

)').

<

<

< <

.0

<





) (

) ...

<





)' (/

)' (+

)' (. O) %- fl

/*%+fl

++O'

)' (+

+- %+fl)' ((

. %+

技能开创未来



3

#



/

)' (, /

)' (, /

)' (+



*)" *"* *"+

&

&

&

&





&

)' (-

)' (.

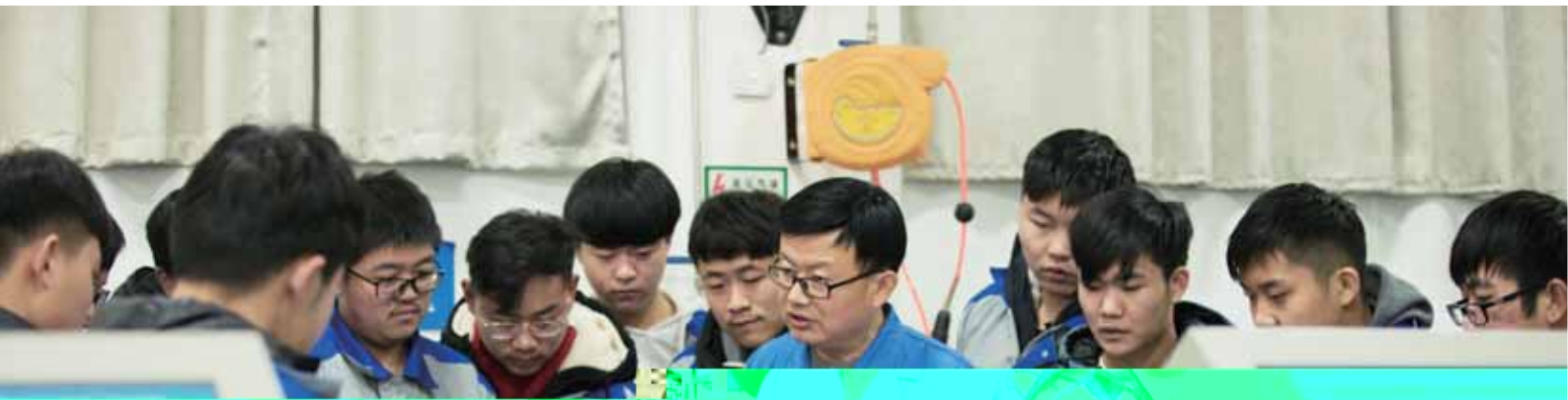

专业是高职院校办学的逻辑起点，是对接社会需求、主动适应经济发展和产业升级的桥梁和纽带。高职院校专业建设唯有与产业同频共振，不断促进其优化升级，职业院校发展才会有旺盛

#





#

+% "



*)

\$

\$



#



))

))

&

<I G

±

: 8;

: 8<

: 8D

: 8GG

G; D

)' (-

)')'

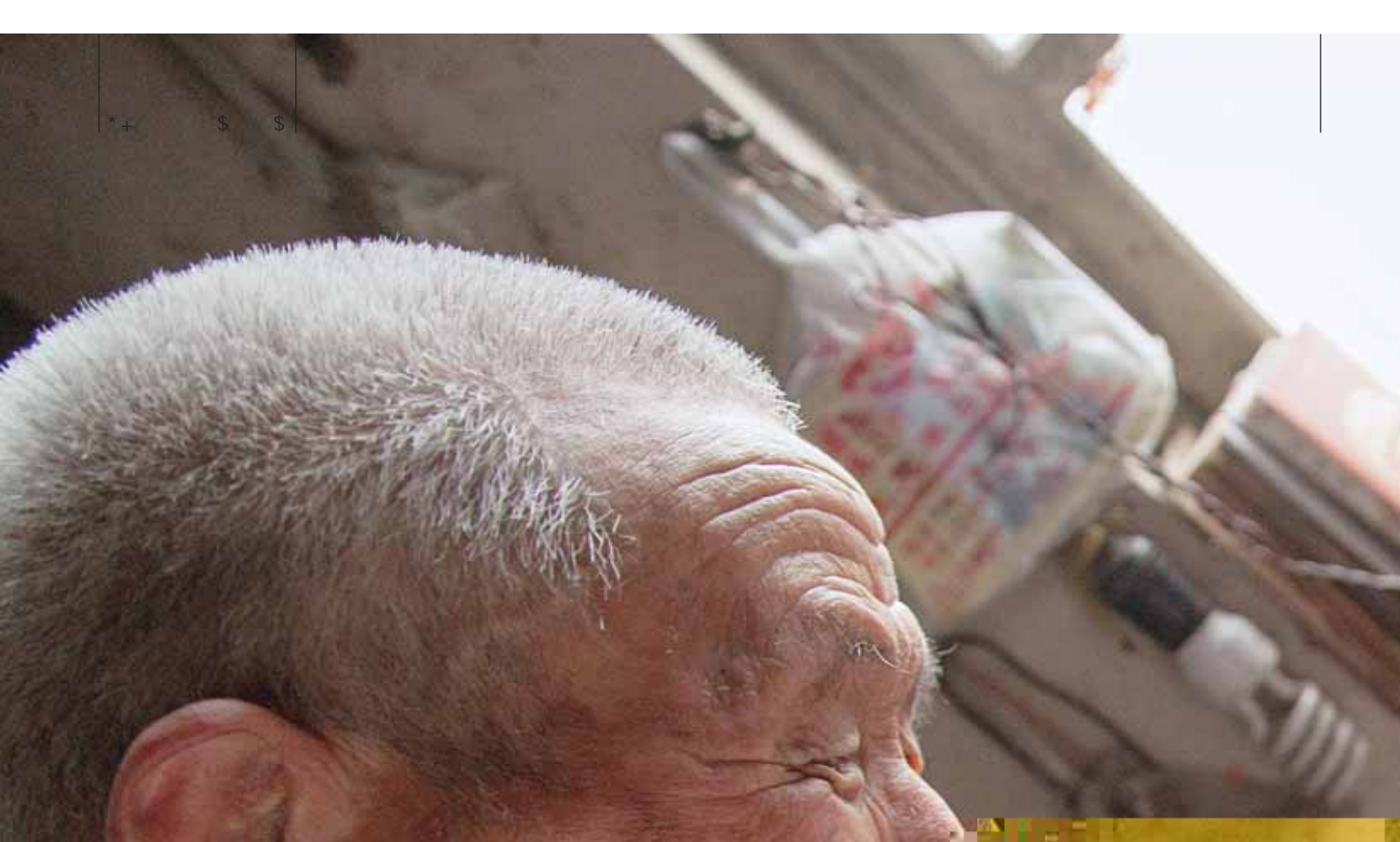

「吟诵」 最美的读书声音

「寻访最后的私塾老人 采录最美的读书声音」

我院开展山东省方言吟诵田野调查工作侧记

引言：“青灯黄卷，独对书案，念不尽圣贤古文，读不尽春秋左传古圣先贤……”，2018年5月25日下午，斜阳正好，园蔬香逸，年将九旬的私塾老人樊德秀先生端坐于没有院墙的老屋庭院中，甲子车辘辘轻打拍子轻敲鼻吟，在杨秀录和陪同人员无不陶醉其中。在网络时代的今天，还能听到绵延三千年的中华古老读书声……古调吟诵，“如听仙乐耳暂明”，恍有隔世之感。



樊德秀



任松筠



张延龄

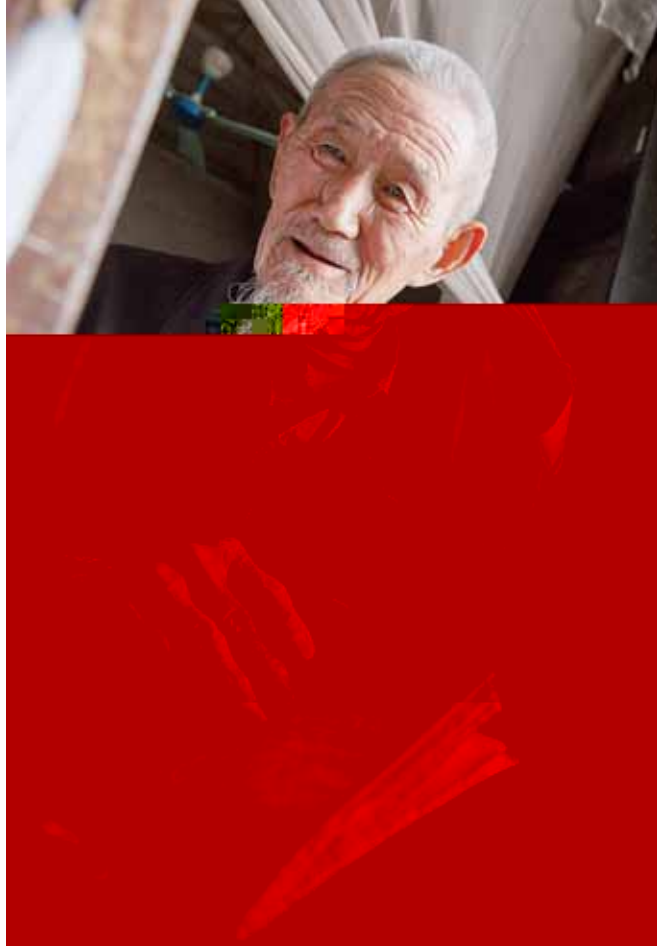

)'(/ ,) .) .

(0*

*

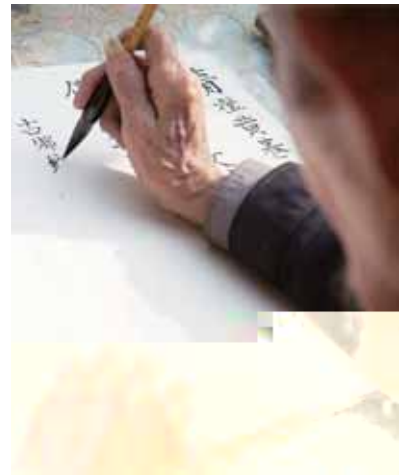

*/

\$

\$

< <

(0**

(0.



(0*+



<



创一个品牌



'(/ +) /



)' (.)' (/



"

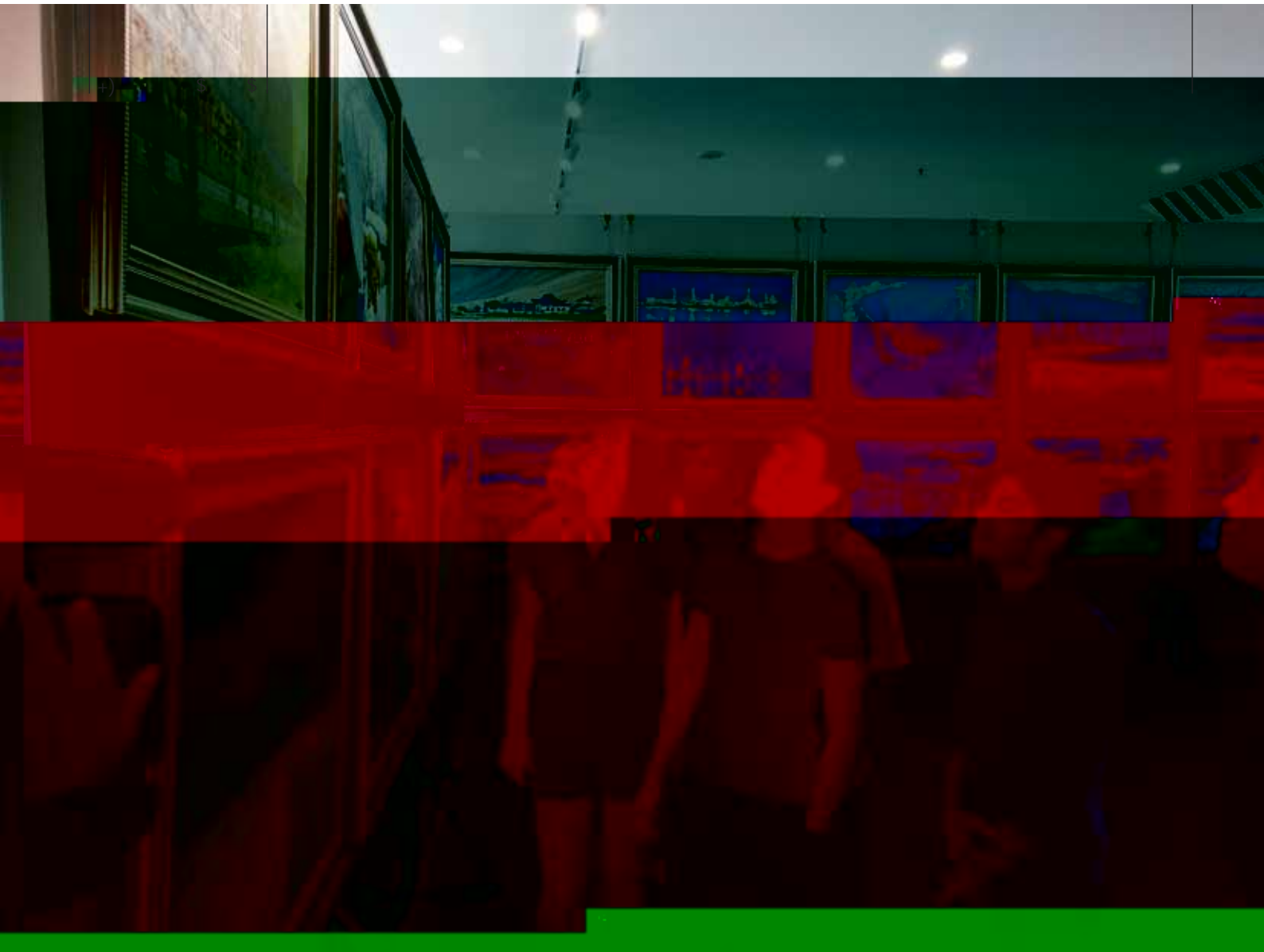

.....

...

...

& ...



)'(/ - ...

.....



)''

*,

)''0

++

\$

\$

)' (.

'&

+

8GG



(

+

+'

)',

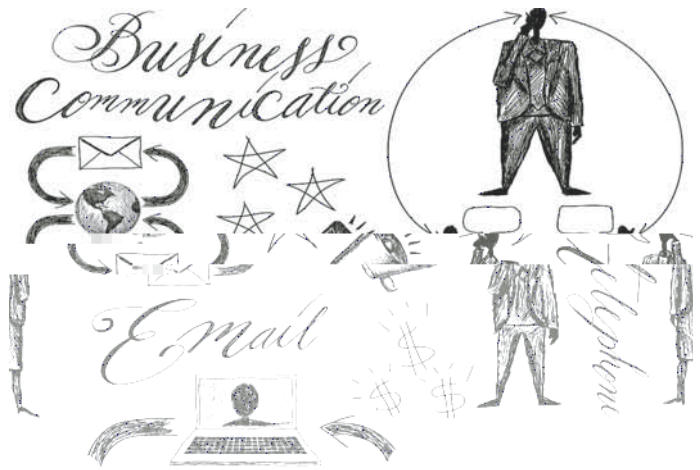

0 **

+

+



)' (



)' (.



)' (.

+

G@





)'(-

*
*
/ *

(
(
/

+ / \$ \$

..

..



&



|

#

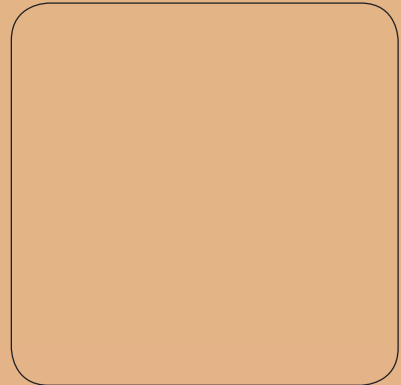
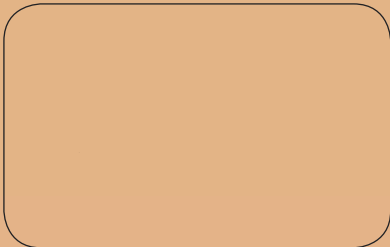

#



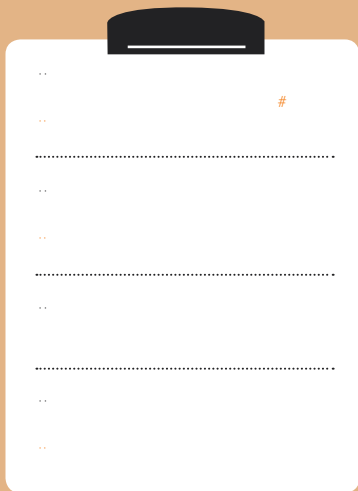

, ' \$ \$

&



)' (. , +

)' (+





"
"
)

)

0, "



ĭ ĭ
'& ''



ž ž
+ ' fl , ' fl
(%)
) ' fl # - fl
ž

✱



#

#

#

#

#

(* +
* + #

#

* ' '

#



(%



(%

... & ...



*)

/*)

*



(u)

*u+



/' fl

)' fl



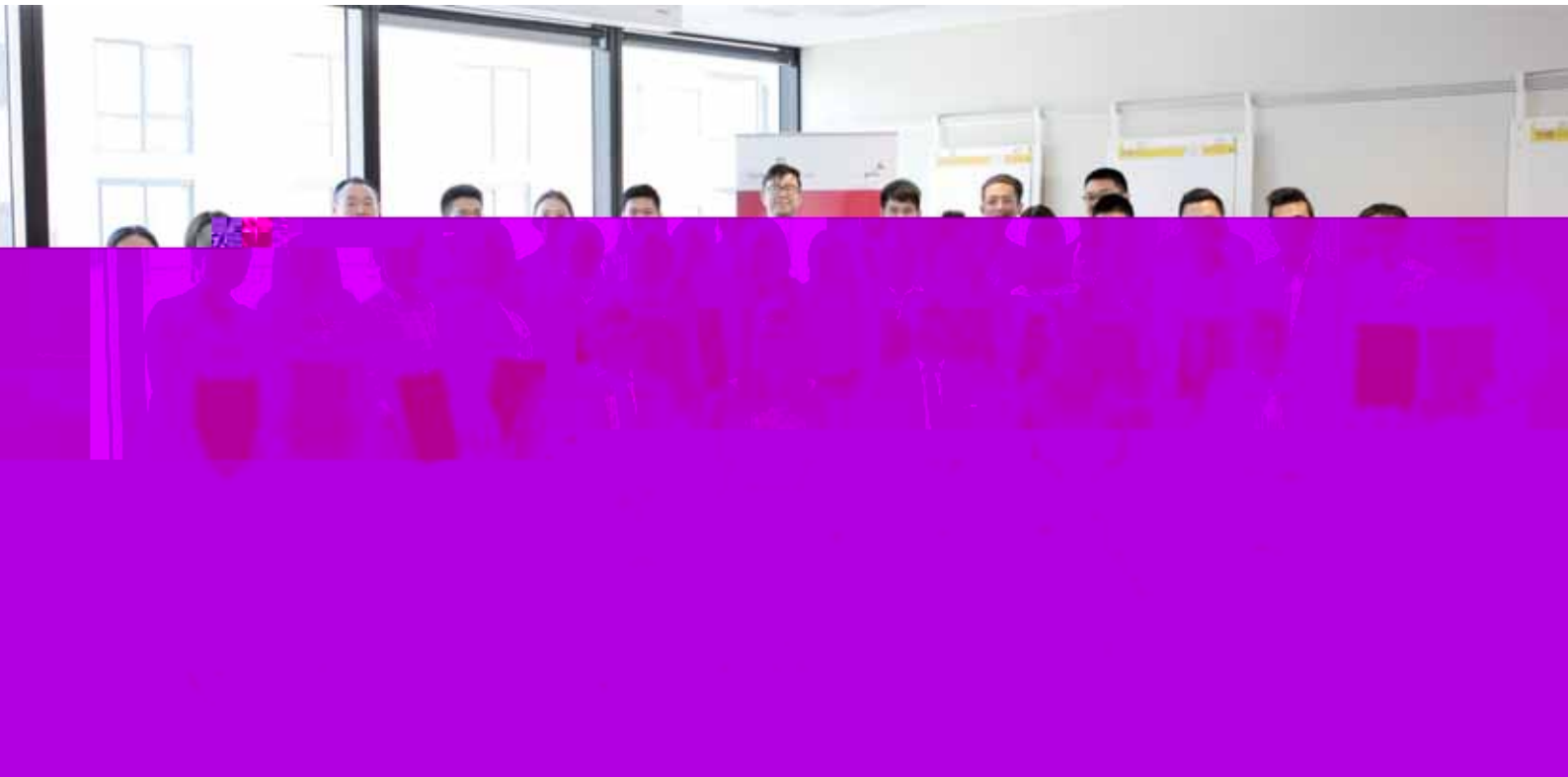
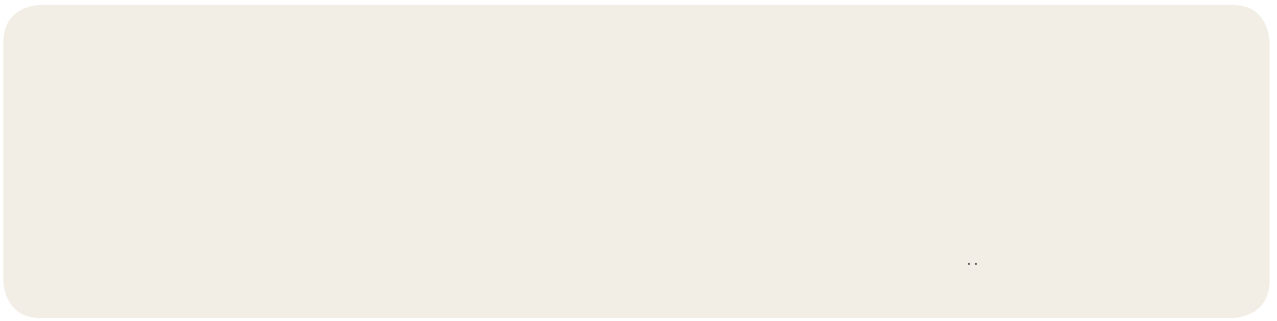

“工匠”资源

强力支撑

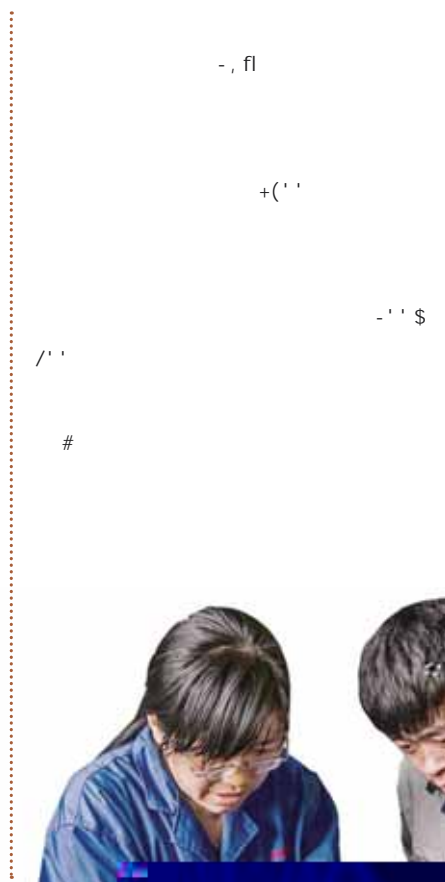

) / fl +
O- fl

)' (+



8Y'k i

)'' '\$''''

(+, '' '\$)''''



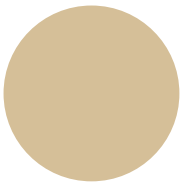

z
z

&
(%
(%0



(%0

)' (. Kf g)'



)' -



- +

\$

\$

FB

)' (*





.....

(

#"



(

)

*

+

-

/

)' (.

)' (.

*+//'

*)- *'

*)+/'

*' /'

)0-.'

)-0)'

)/0/'

),.)'

)' (.

ž*+// ž

ž*)- * ž



)' (.

+.. 0

++..

0/fl /) fl

ž /fl ž

"



)' (.

ž ' fl ž

)' (.

ž0/fl ž

#

ž0' fl ž

(

ž) 0fl ž

ž* +fl ž

\$"

)'

)'

.)'

..

)')''))

(, ' ,'

..

)')' (0

*

)')'
)''))



..

)' (* ('

)' () ((

(..

, - (*

)' (* ()

%

<

#

<



#

)''

)'(+

)'''

)','' ,''''

),''

<			
#	#		
#	#	#	
#	#		



* **

+(*0

#

)' (* (()-



ŽD Xj d n # 0. ' ž

Žr \ [\ i (0. / ž

ž9Xe [I i Xž

)

; %f i k f e

* *

N %&g Y i \ \ z

? %% k k f

\$

\$

*

9if ne

(

)

*

+

+

.

\$

\$



)

(

*

(



\$

\$

, ,



+

)

+..

,

*



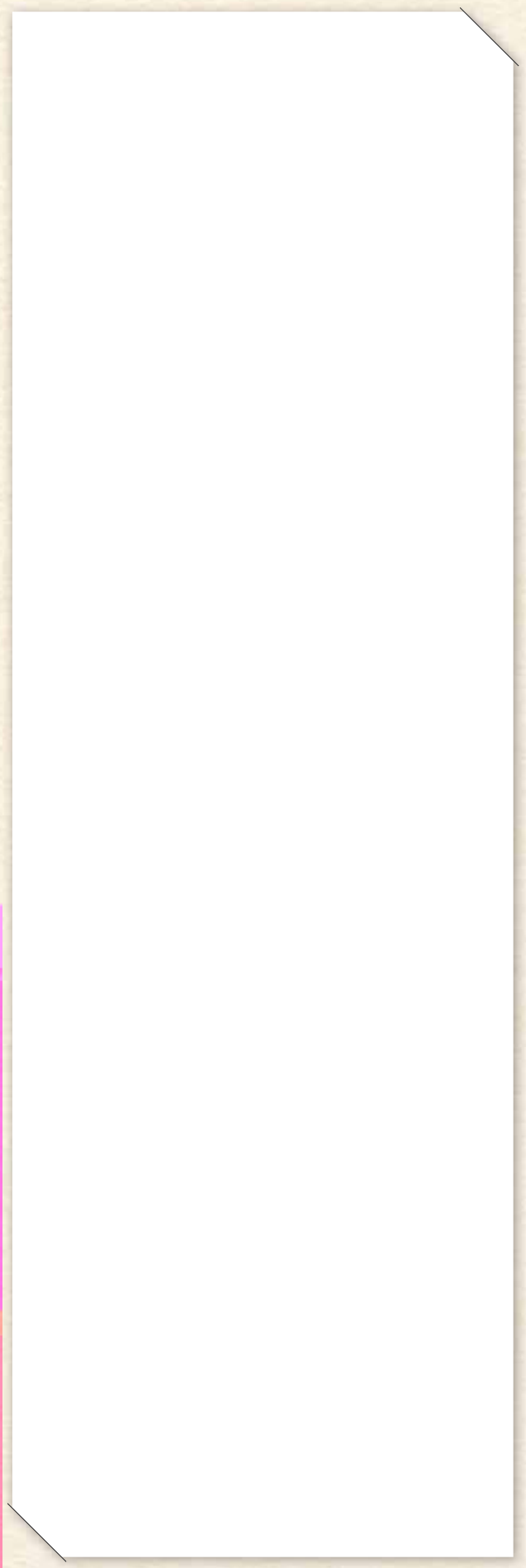
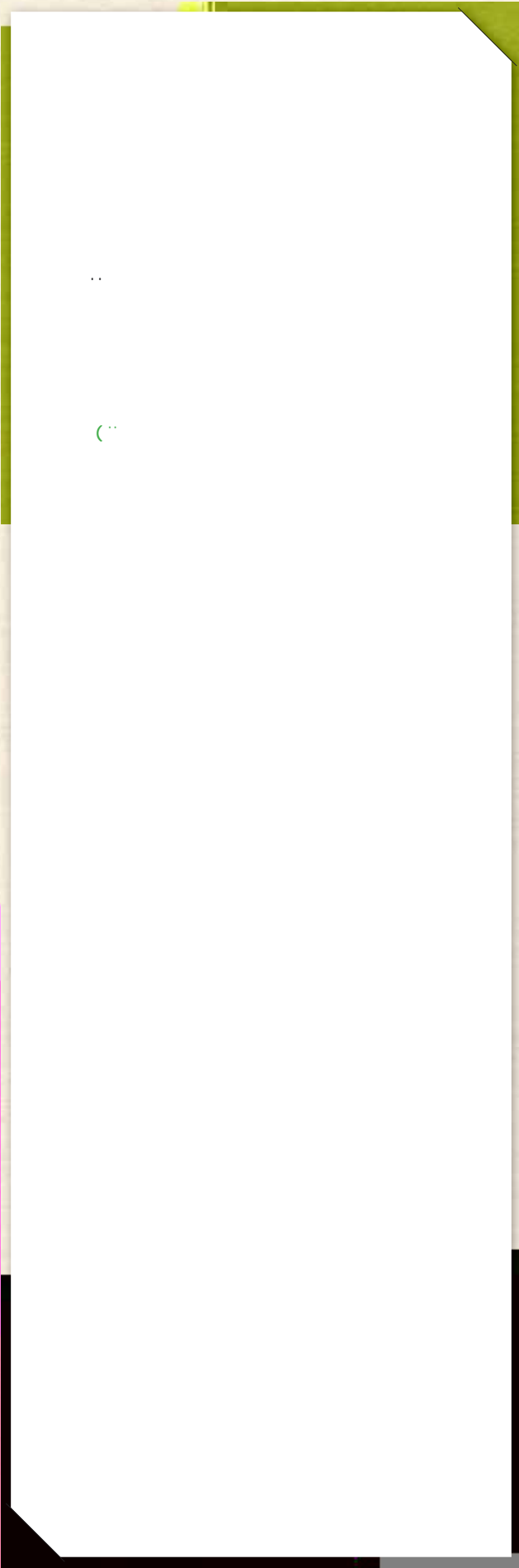

\$

\$

..

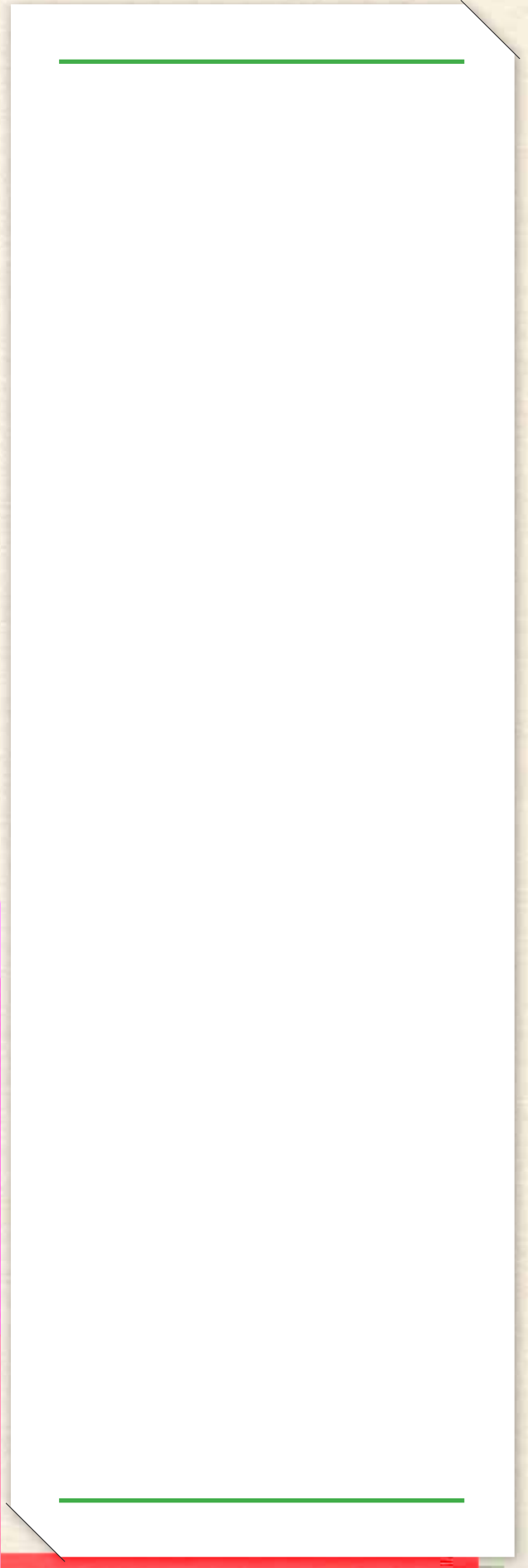
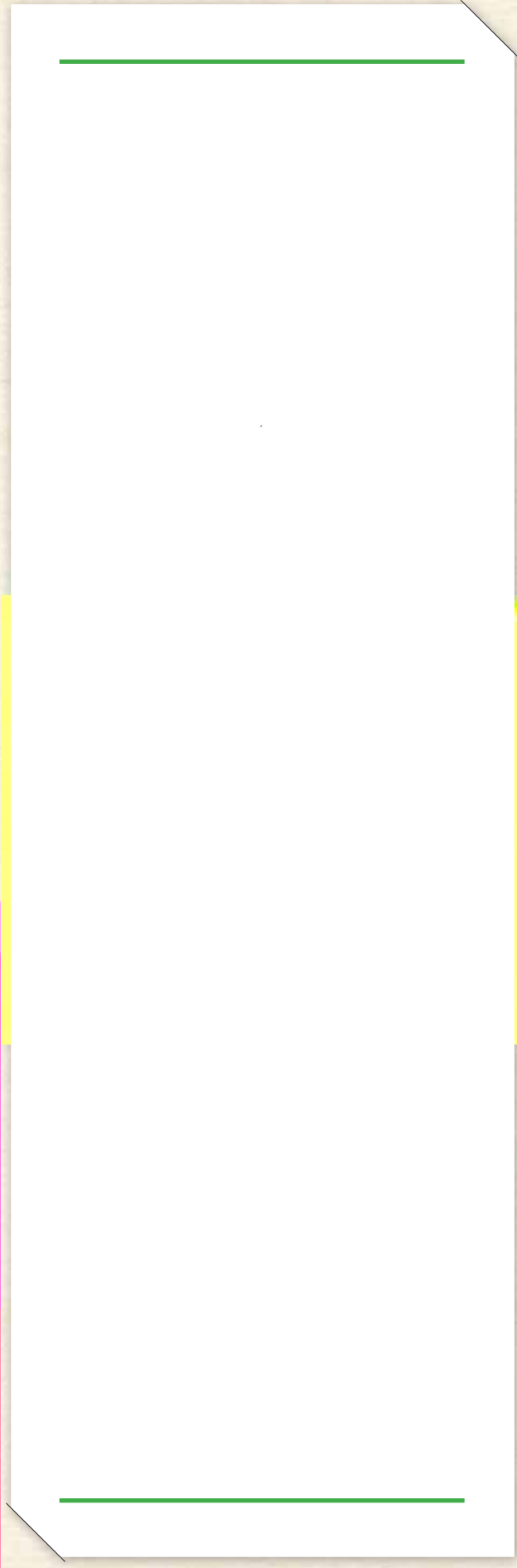

* **

. ' fl

- , fl

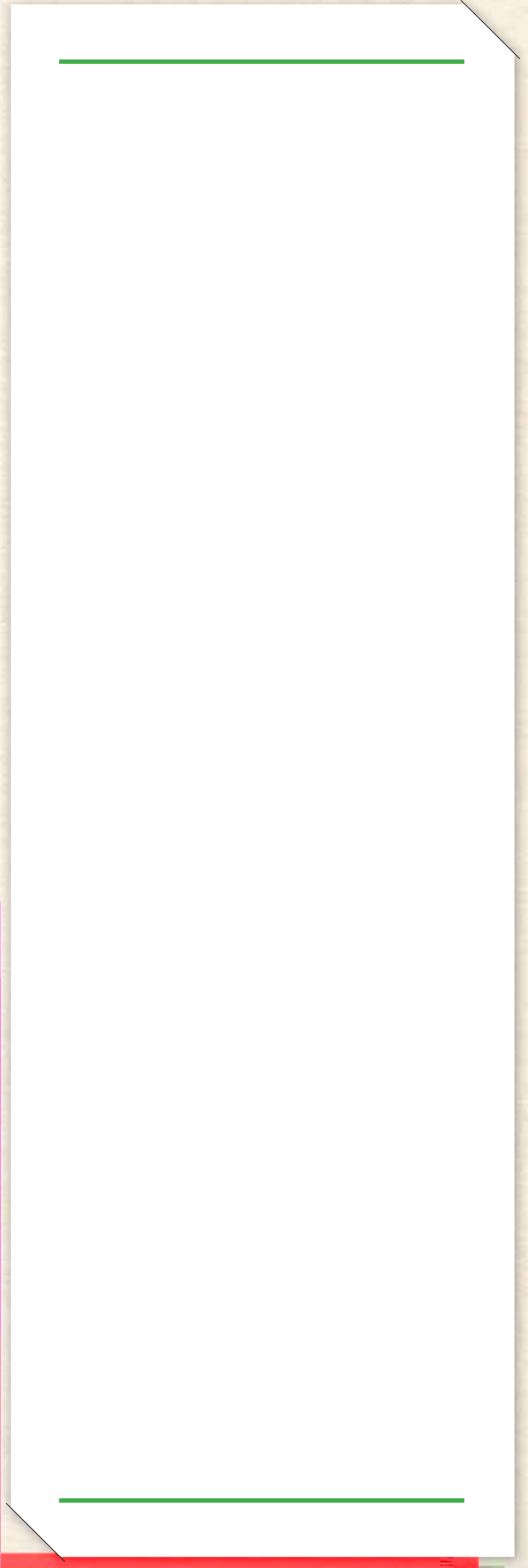
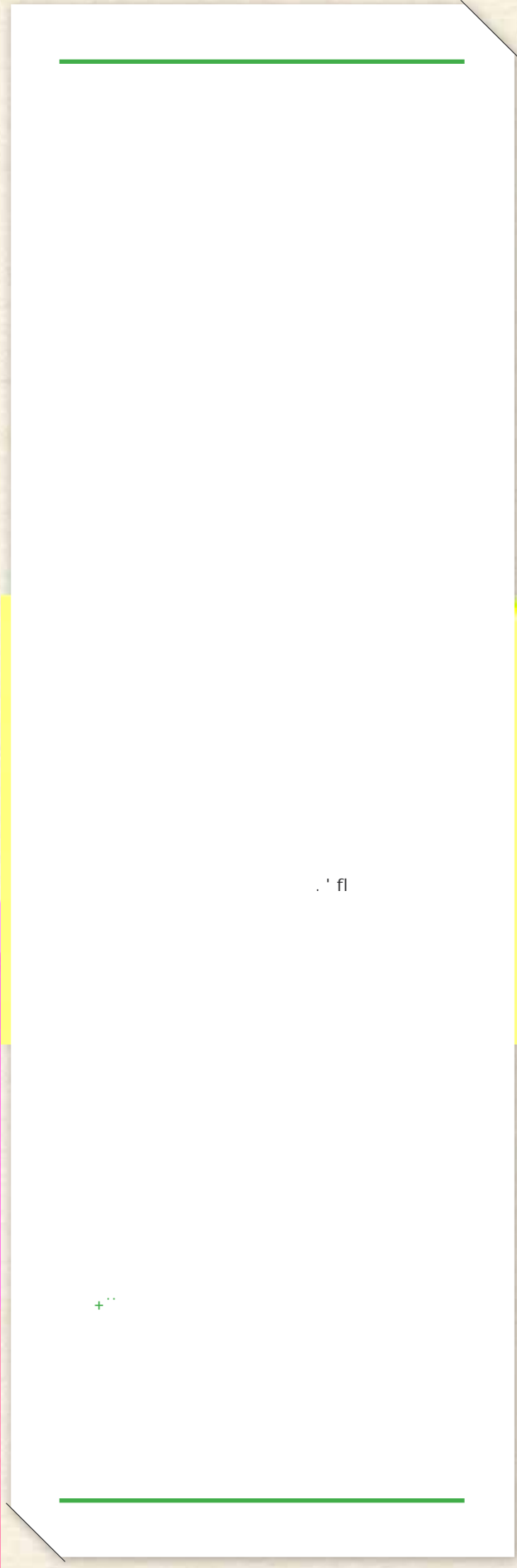

. ' fl

+ "



...

(

)

*





("

(/-)

: 9<

K8=<

)' , ' -'
(0/,

(00(
(00)

)'' +

)' (')'''

)''

ž ž

* ..

)' ('

)%D N g

* , ''

, ' ' BN g

"

T

)" (

+((

(
(

+

#

#

#

2

2

2

#

2

#

2

y

)' (, O+%*fl

+..

]

- y y

t

x

#

#



.....

(

)'(')''

)' (+R O T ž

ž

)''

)' (.

/-

\$

\$

)*

0

(+

= L

)' (-

* ..

#

#

#

+ ..

//

\$

\$

.....

#

(

)
)'

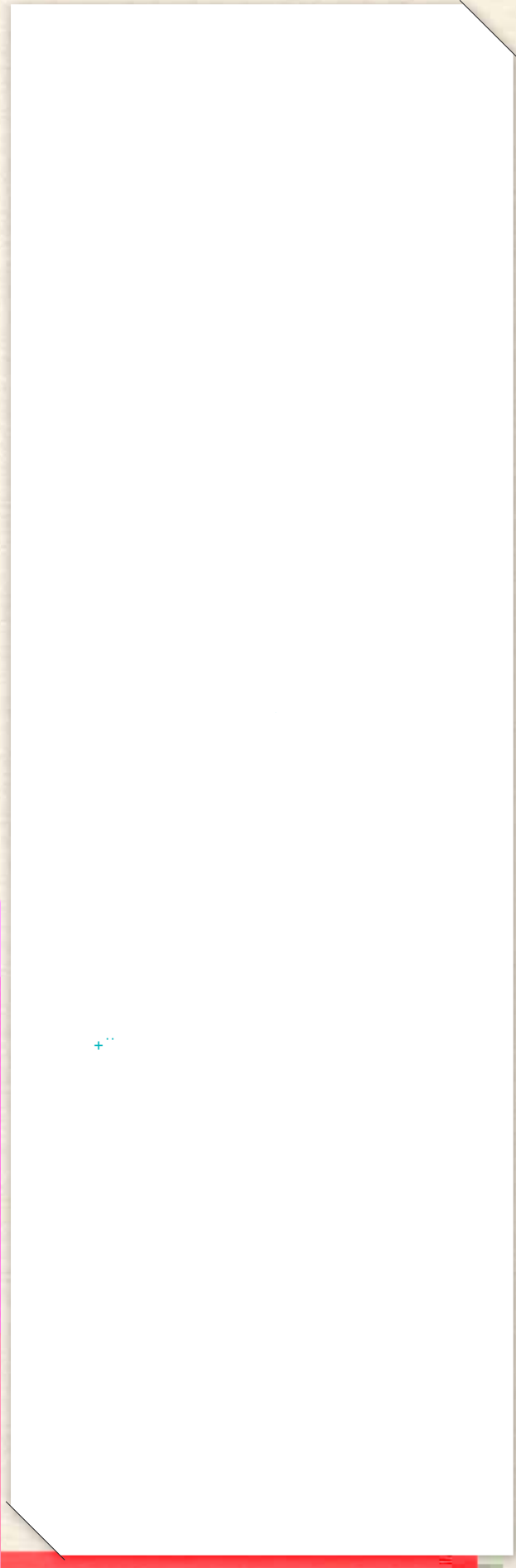
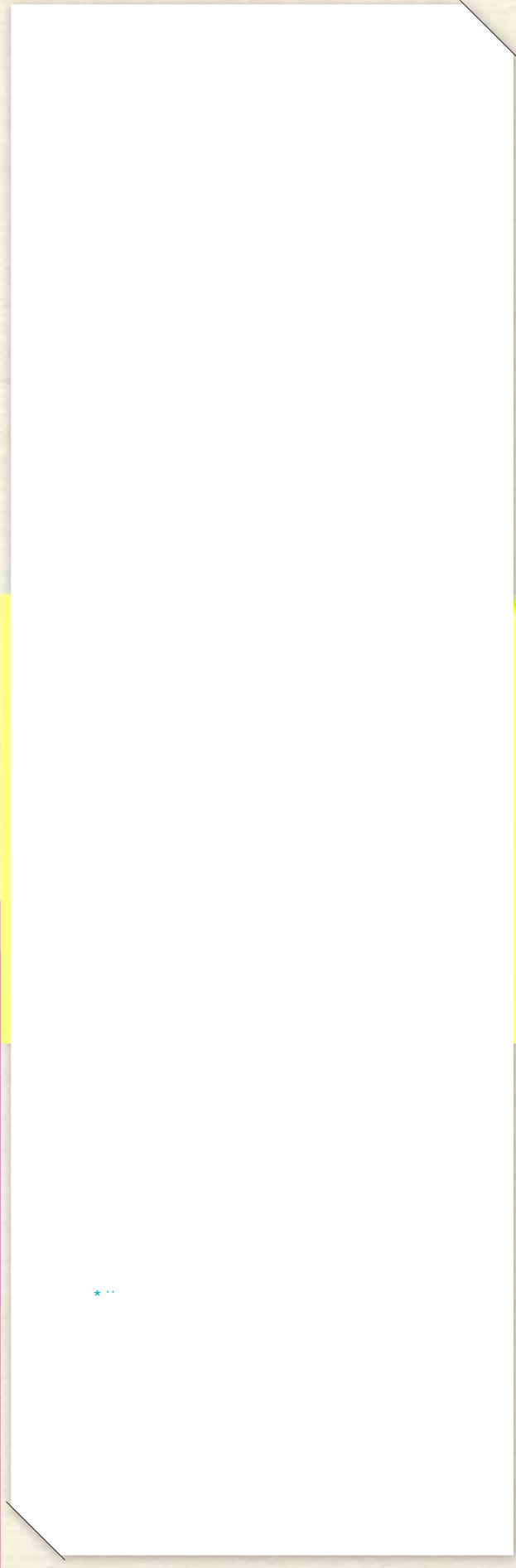

七

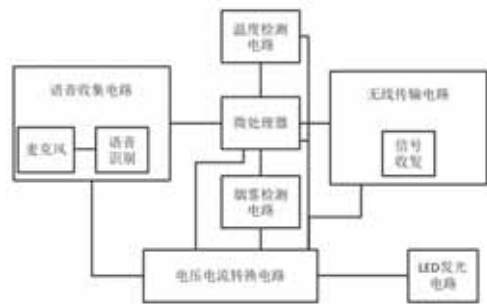

(%)

)%

)' (/%- %.

)' (/%0%+.

)' (/(' * , *0/- %

: E (' /+0. 0() 8

)' (/+% /

)' (/%0%+

)' (/(' * , *0/- %

: E (' /+0, +(, 8

C<;

C<;

C<;

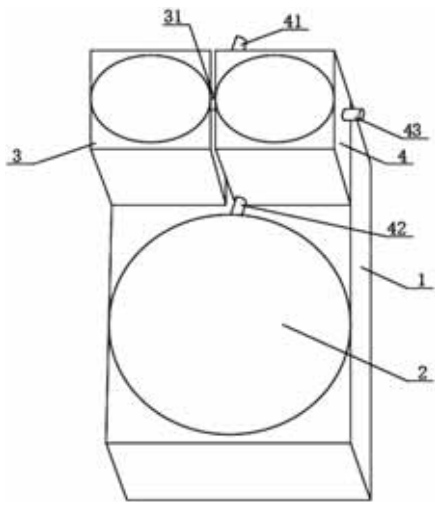

)' (/%)%(
)' (/%. %
)' (/(' (*,)0%
: E (' /**+-' -8

R



)' (/+%
)' (/%' %0
)' (/(' * /0') /%
: E (' /- . /- +) 8

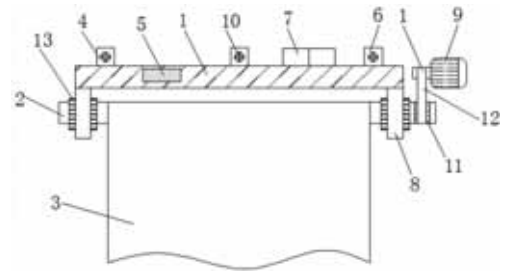

)' (/+%0
)' (/%0%+
)' (/(' *, ,) ()
 : E (' / , + ' * - ' 8

8;

Q^9\

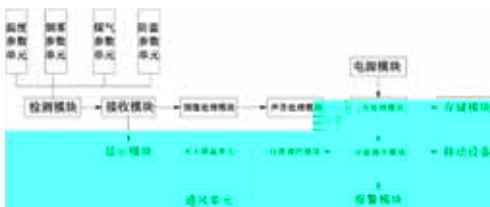

8e[if`[\$8i[l`ef

)' (. %' %/
)' (/+%*
)' (.)(+*)+/%
 : E)' .)*) - +OL

8e[if`[\$8i[l`ef

8e[if`[\$

8i[l`ef

N @@ 8e[if`[\$8i[l`ef

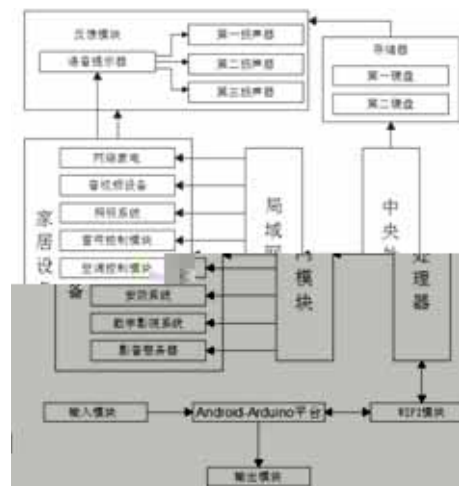

8e[if`[\$8i[l`ef

)' (. %' %.
)' (/%- %,
)' (.) (** +() *%
: E)' . , ' +/O(L

N `≡`

GD) %

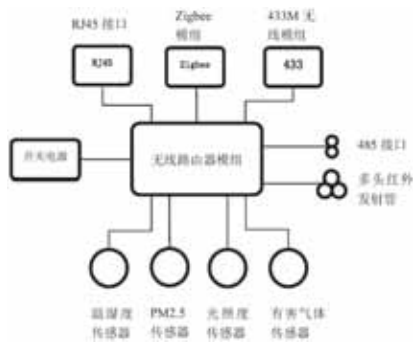

7

)' (. %, %/
)' (. %' %*
)' (. (' * , ' , ' , %

: E (' .) + . / - / 8

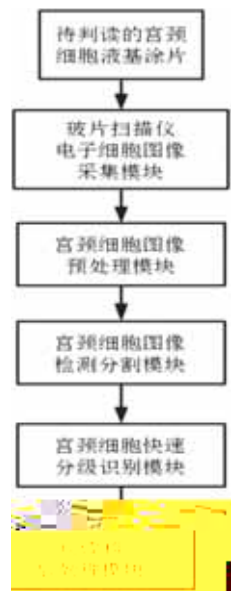
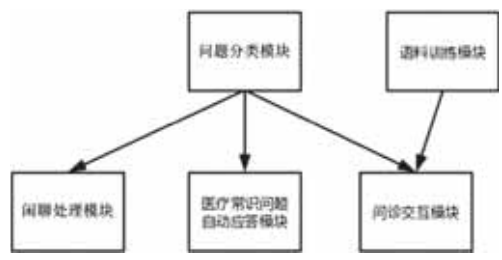

? GM

)' (. %, %/
)' (. %' %'
)' (. (' *, (' - + %
 : E (' .) . + * / - 8

)' (/ %- %'

)' (/%(%'
)' (/(' - *,) - *%
: E (' // * - , . + 8

8;
; 8

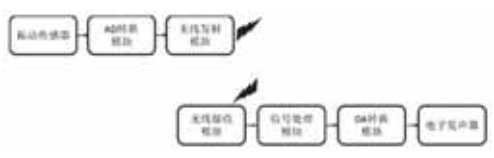

)' (/%, %/
)' (/ % 0 %/
)' (/(' + * ' ')' %
: E (' / , +) - * (8

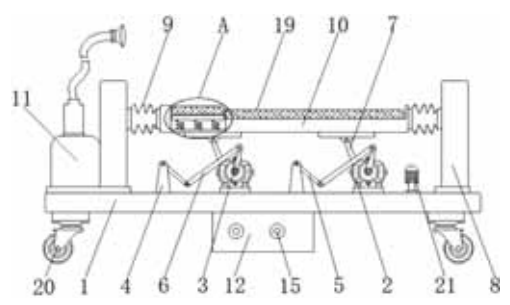

)' (/ % + % 0
)' (/ % 0 % .
)' (/ (' * ((0 , / %

: E (' /, (' +0, 8

, //

, //

)' (. % (%.
)' (/ % + % +
)' (. (() ' * ' + / %
: E (' . O, (+ / , 8

#



) +

#

)' (/ % + % '
)' (/ % ' % O
)' (/) ' , .) (((%
: E) ' . O O) . O ' L

GC:

GC:

GC:

I J + / ,

GC:

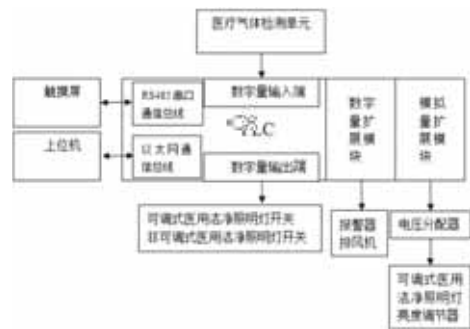

GC:

)' (. % / % *
)' (. %) % 0
)' ((' .) . . -) %
 : E (' . ,) - / ' 0 8

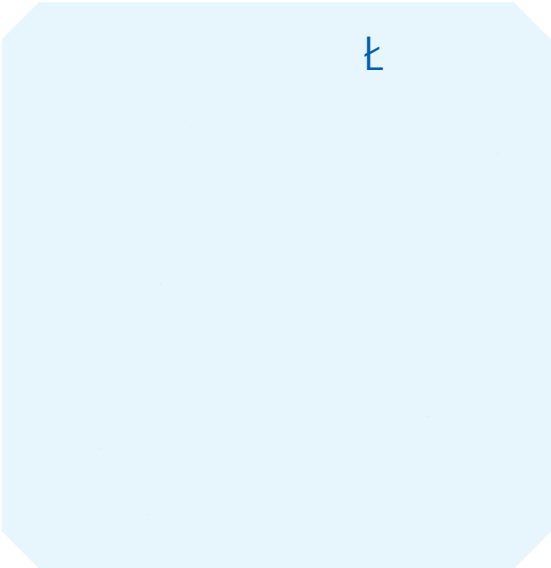

)' (/ % , % ()
)' (/ % (% -)
)' (/ (' + 0 (- 0 ' %
 : E (' / . - 0 (. * 8



)' (/ % + %)
)' (/ % (% -
)' (/ (') / (-) / %
 : E (' / . + +) . (8



)' (. % ' % +
)' (/ %) % 0
)' (. ((' ' ' + - * %
 : E (' . - . 00) * 8

Ž(z
 ž(z
 Ž(z
 Ž(z



)' (/ %, % /
)' (/ % 0 % +
)' (/ (' + / *) + %
 : E (' / + 0 + / ' (8

(' (

\$

\$

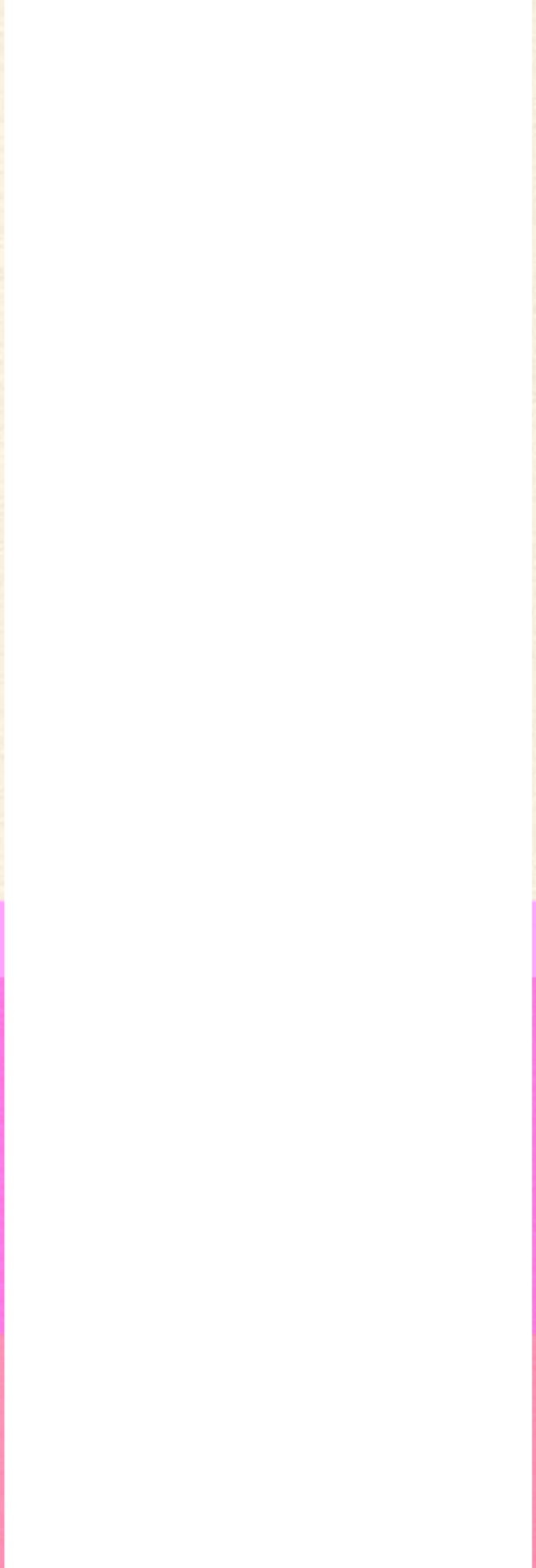
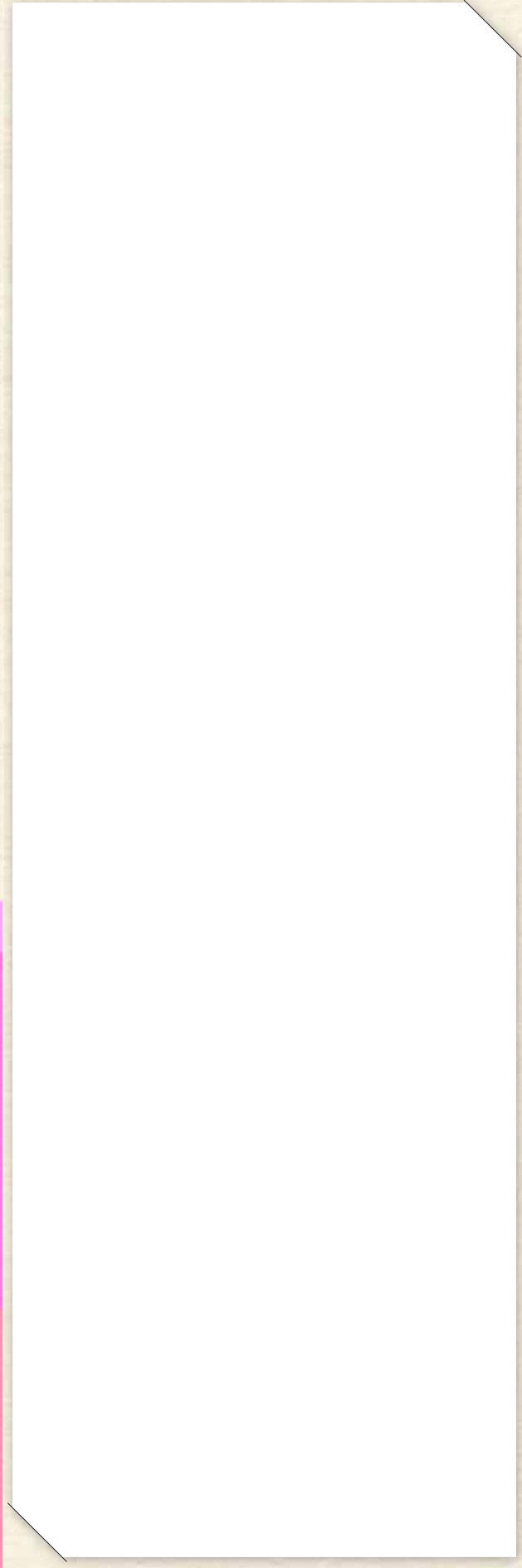

(')

\$

\$

)' (/ % + % ,
)' (/ % (% -
)' (/ (' * . . 0 // %

: E (' / . - + * 0 (8

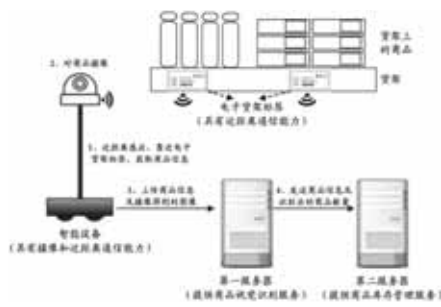

七

)' (. % 0 % /
)' (/ % (% -
)' (. ' / + ' - // %

: E (' . , 0' - + - 8



)' (/ % - % *
)' (/ % (% *
)' (/ (' - , , (' 0 %

: E (' // . * - 0 . 8

七

)' (/%- %)
)' (/%(%-
)' (/(' - +0) 0' %
: E (' // *') +(8

#

)' (/%(%.
)' (/%/ %*
)' (/(' ' +- ,) %
: E (' / * - + + -) 8

J(%

J) %

J * %
J + %

J, %

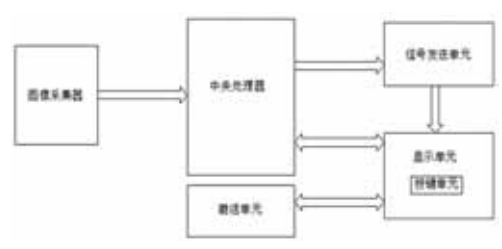



)' (/%. %/
)' (/%' %*
)' (/(' . / . - *(%
 : E (' / - 0 + / * / 8

K: G&E

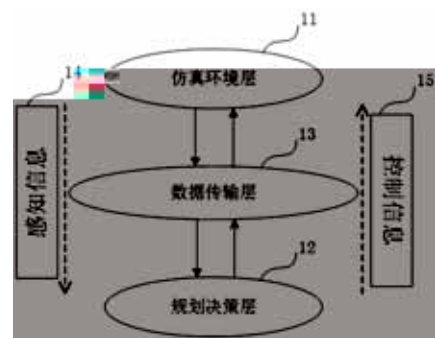

)' (. %) %0
)' (/%, %(
)' (. ((+/) - ' - %

: E (' . O . .) * 8



)' (/ %+ %)
)' (/ % 0 % ()
)' (/ (' *) , 0 /) %
 : E (' / , - * . +) 8

J (T ;
 : 8 ; J) 1

J (* ;
 * ;

J * 1 J *
 J + 1



)' (. %) %
)' (/ % , % 0
)' (((* (. + 0 * %
 : E (' / ' 0 ((+ - 8

P O P
 O O

)' (. %, %'
)' (. %/%+
)' (. (' *) *, , ' %
: E (' . ' (-+. (8

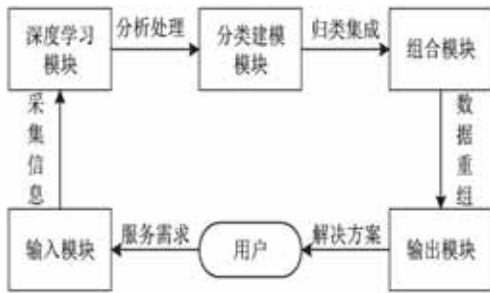

)' (. %' %'
)' (- %*%0
)' (.)' /+/. 0, %

: E)' , ' . . , (+L

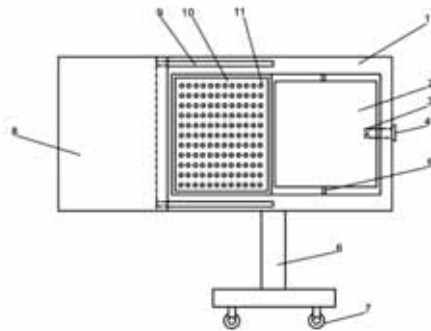

)' (. %) %'
)' (. %0%)
)' (.)' () +00(%
)' - +/(/ .) L

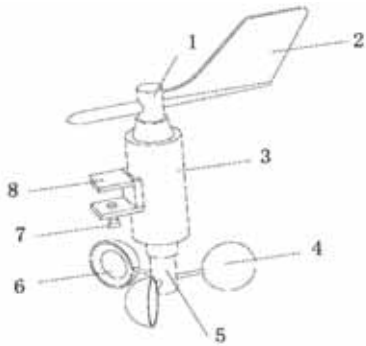

)' (--%(%.
)' (--%-%/
)' (-)' ' (()') %
 : E)' ,) // - * + L

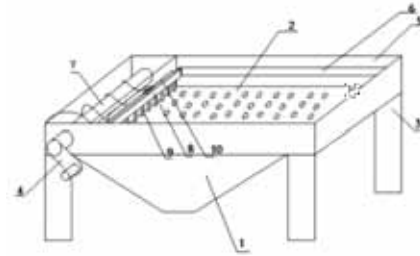

)' (. % (% -
)' (. % 0 % ,
)' (.) ' ' , * - . - %

: E)' - + 0 , (. . L

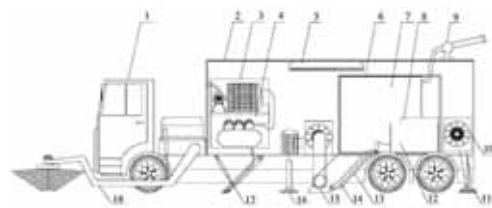

)' (. % . % (
)' (/ %) % *
)' (.) / O (. - %
: E) ' . ' * , O , , L

(' \$ * ' b ^ & d)

J

J

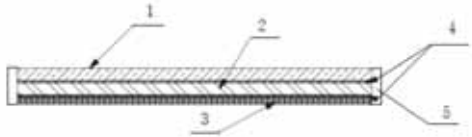

)' (. %) % O
)' (/ % (% O
)' (.) (. /) , * (' %
: E) ' / ' . ' - (- L

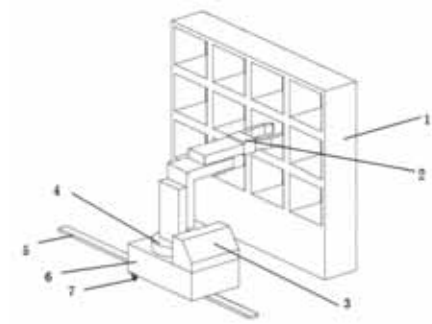

)' (. %) % O
)' (/ % (% -
)' (.) (. - ' . * %
: E) ' / ' O , (O / L

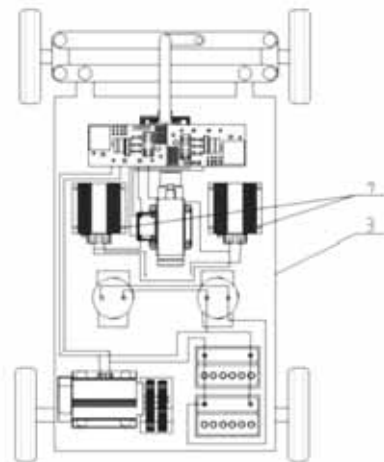

|

|

|

\$

\$

((



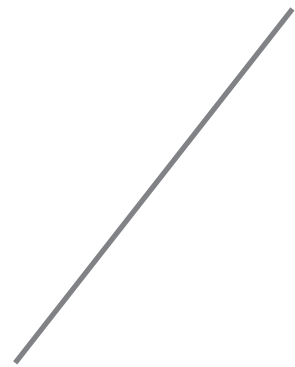

)' /



&\$%- \$%

- +
%\$\$\$+'
f\$)' &L', \$% (* -

, , - %%- (.....#%* + % &
&\$%- ' % '&\$%- ' %

') \$*, %*' (- "\$\$\$

f\$%(\$L) &&) +%) *